

Variante D400 und C250

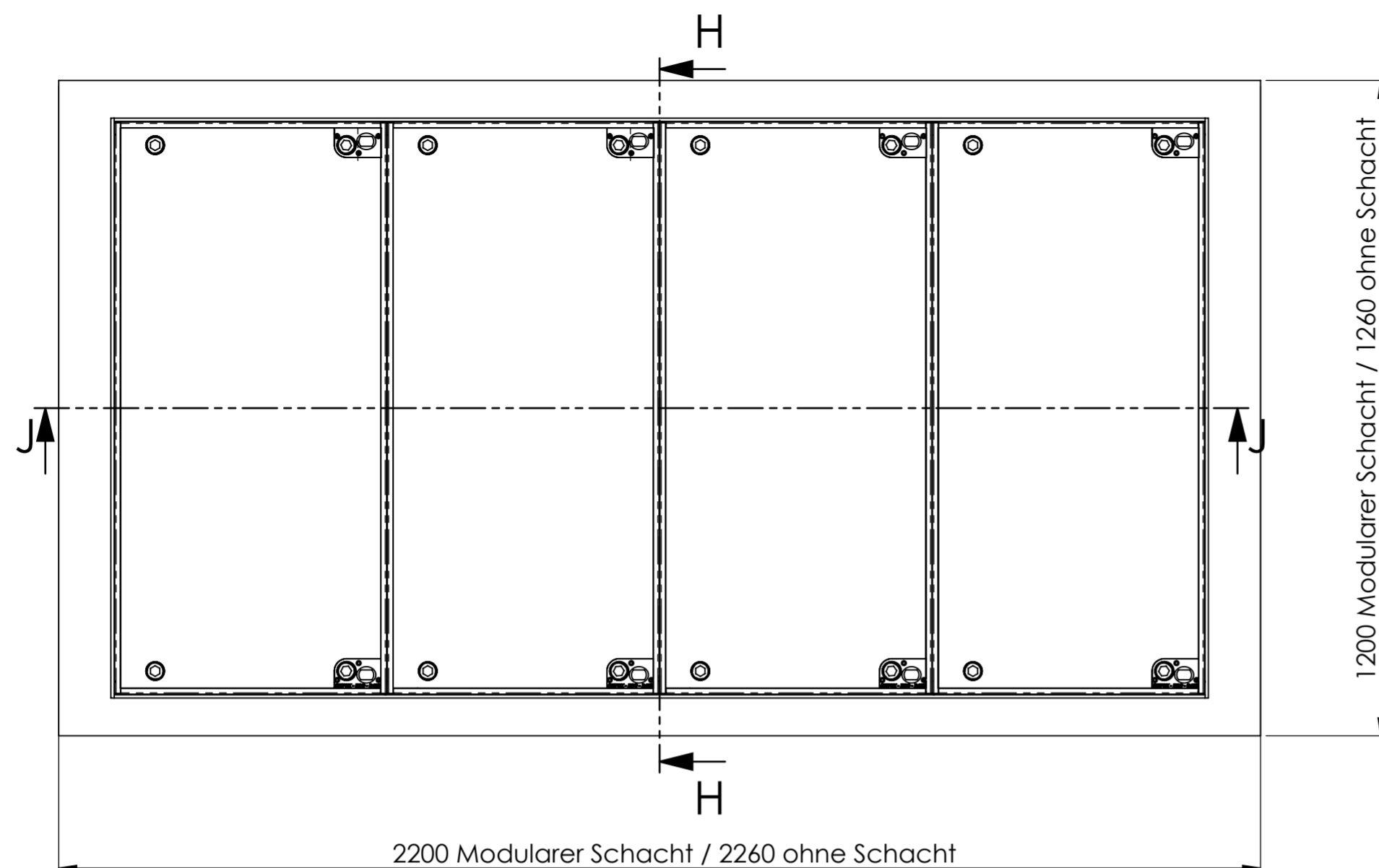

SCHNITT H-H

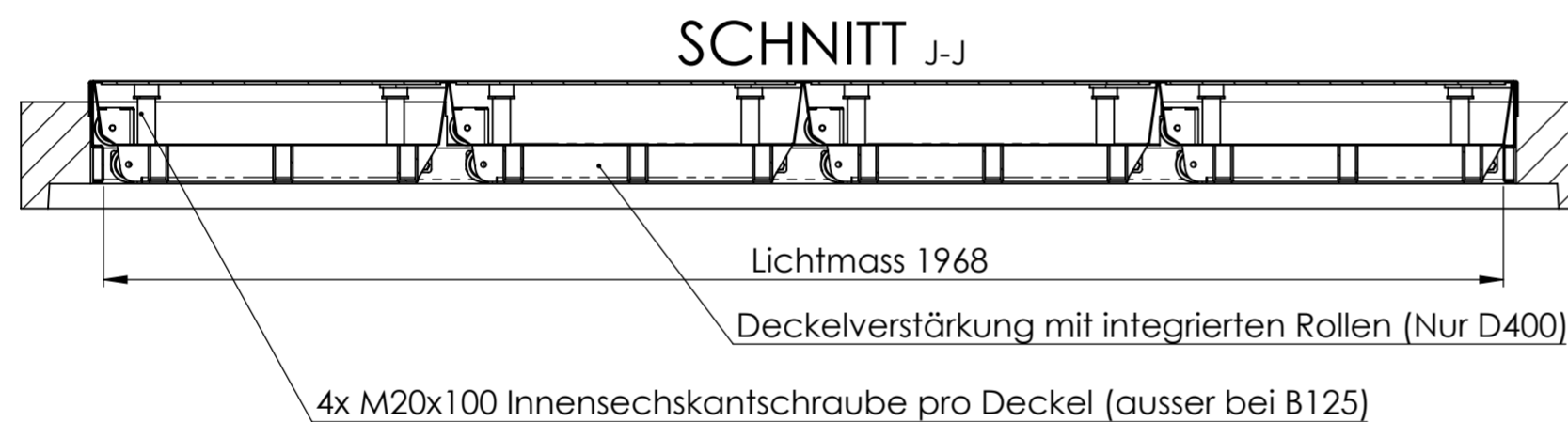
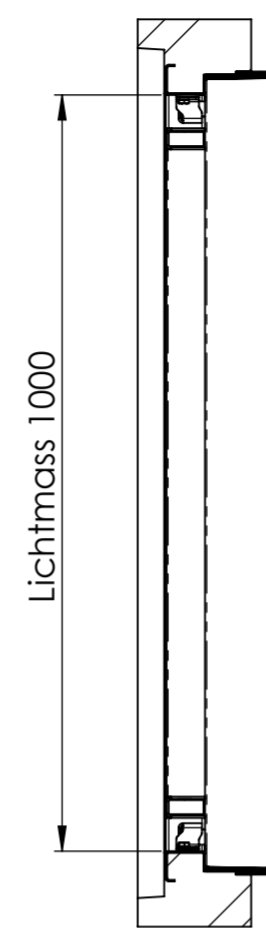

Betonkranz Optionen

Bis OK Betoniert für modularer Schacht
Beton Hell / Schwarz

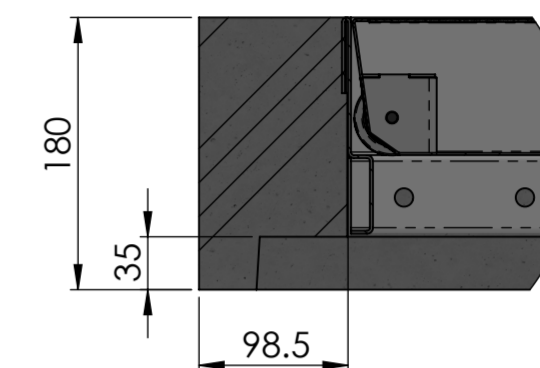

Bis 3cm Betoniert für modularer Schacht
Deckel Schwarz

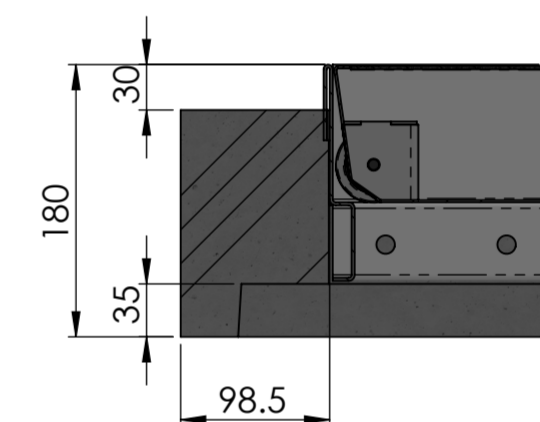

Bis 3cm Betoniert ohne Schacht
Deckel Schwarz

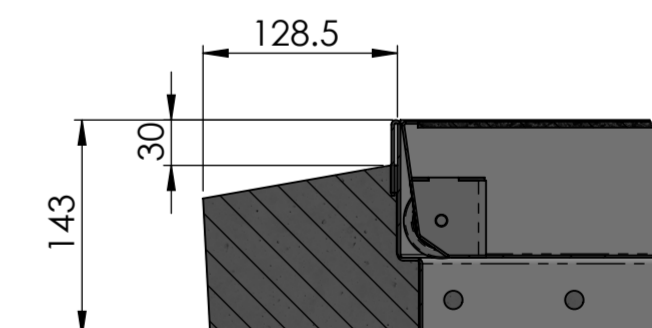

Variante B125

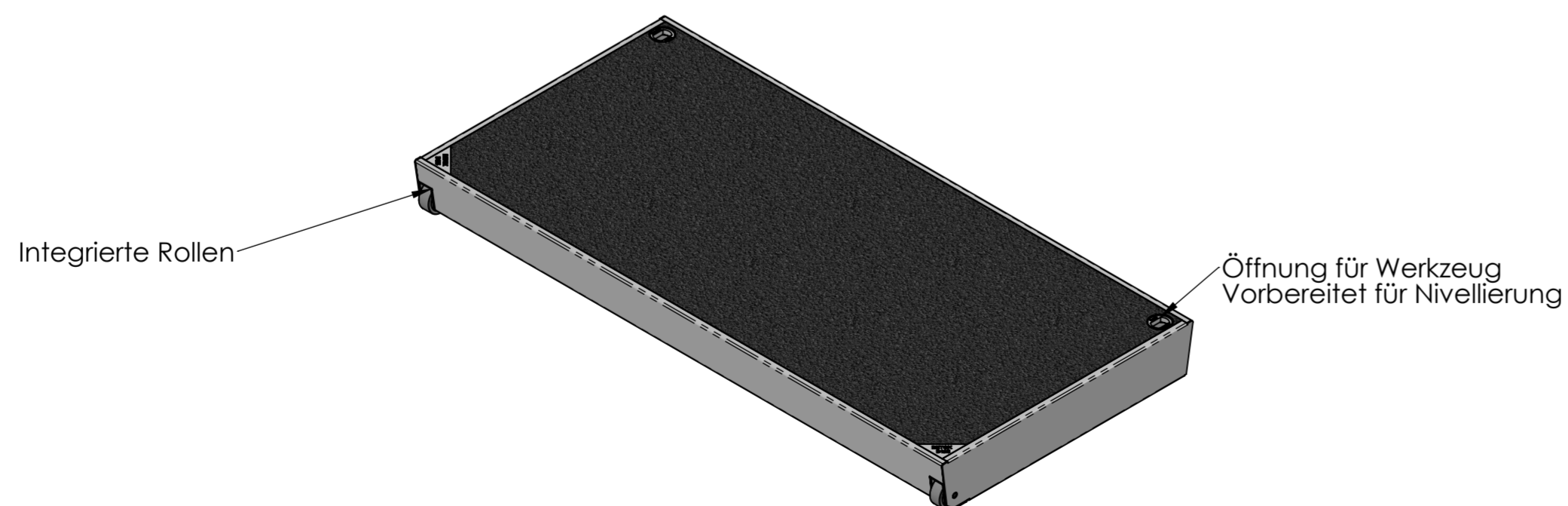

Allgemeintoleranzen ISO 2768-m		Material:		Gewicht:	
				kg	
ECO.1020.X.B.xxx.4D			Massstab	Gezeichnet	MH
			1:5	Geprüft	MH
				Datum	10.03.2022
				Name	
BETOX Innovative Schachtsysteme		Format	Zeichnungsnr.		
		A2	019-078		